

CUSTOMER: \_\_\_\_\_

REFERENCE: \_\_\_\_\_

## HS-15000 RO WATER TREATMENT SYSTEM BY WATTS® PURE WATER

### PRODUCT SPECIFICATION

#### APPLICATION

Today's ever-changing water quality issues demand that point-of-use water treatment systems become an essential component of equipment applications. Because municipal water treatment facilities are designed to reduce mainly biological contaminants, they do not decrease contaminants that affect the performance of water dependent equipment. The Watts HS-Series water treatment systems are designed specifically for use on applications found throughout the healthcare industry, such as point-of-use steam generators, instrument and cart washers. When used as suggested by the manufacturer, The Watts HS-Series water treatment systems significantly reduce or eliminate boiler scaling and instrument spotting. Not intended for drinking water.

#### BENEFITS

- Extends equipment life
- Provides "spot-free" rinse water at a fraction of the cost of Deionization (DI) water
- Reduces or eliminates boiler scale
- Increases boiler heating element life and efficiency

#### EQUIPMENT FEATURES

- Complete pre-treatment
- Sediment filtration removes dirt, sand and rust
- KDF media filter reduces iron
- Carbon filtration removes chlorine and other VOC's
- TFC reverse osmosis membrane reduces up to 99% of TDS
- Complete post-treatment
- pH adjusted
- TDS balanced to ensure proper conductivity of water
- 1-year warranty
- Factory performance tested and sanitized
- UL listed controls

#### SYSTEM PERFORMANCE

When used as suggested by the manufacturer, the Watts HS-Series water treatment systems eliminate up to 99% of the following contaminants:

- Total Dissolved Solids (TDS)
- Volatile Organic Chemicals
- Hardness (CaCO<sub>3</sub>)
- Chlorine Additives



#### MODEL SELECTION

- Float Tank (#61301605531)
- Pressure Tank (#61301605532)

#### QUALITY STATEMENT

Confidence in the Getinge Group is the most important quality criterion. This must be the hallmark of all of our external and internal commitments, activities and products. Products and services supplied by Getinge must conform to the agreed terms and expectations to ensure recommendations for further business. The achievement of these quality goals is the basis for a continued competitive and successful enterprise.

#### WARRANTY

Watts HS-Series water treatment systems are warranted for one year. Labor for repairs is provided for the first 90 days following equipment installation and start-up. Warranty repairs are performed Monday-Friday from 8:00am-5:00pm, excluding national holidays.

# HS-15000 Water Treatment System FT (P/N 61301605531)

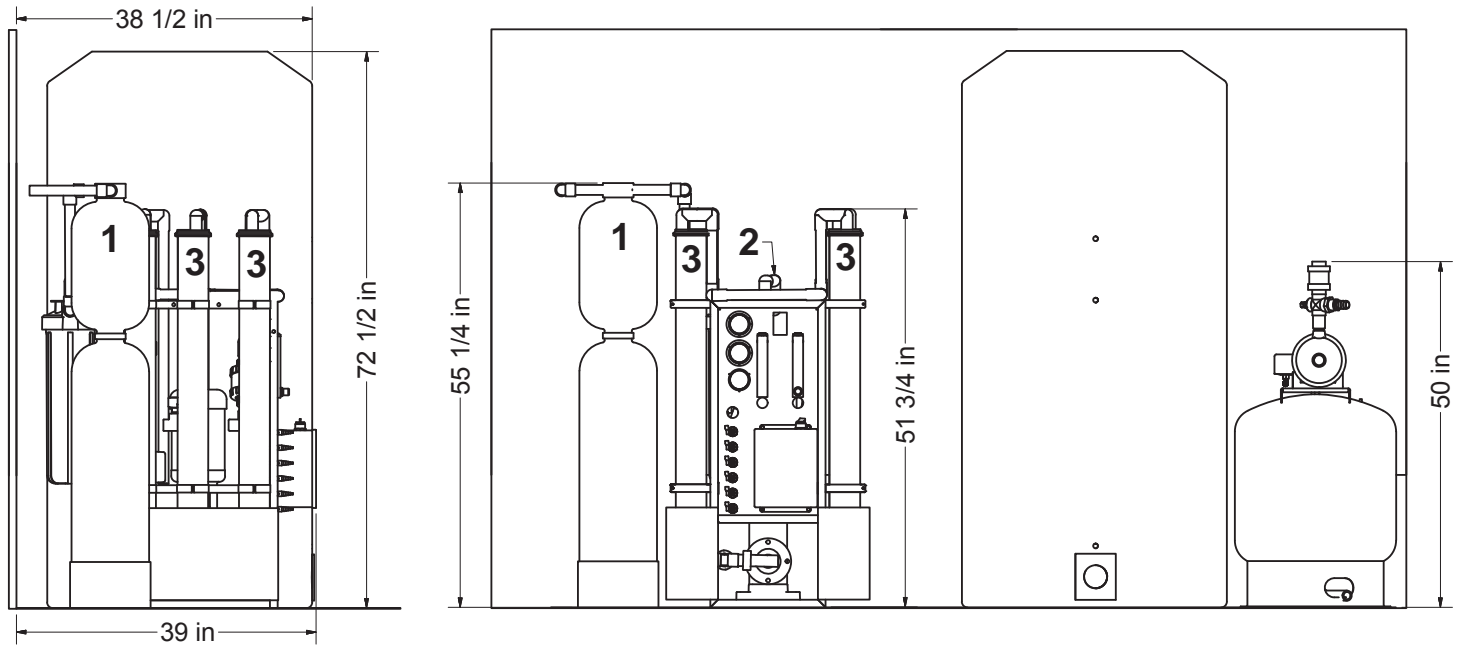

## NOTES:

### 1) ELECTRICAL REQUIREMENTS:

• RO System: Single Phase 208/230 VAC, 15/13.5 Amps, 60Hz; Branch Circuit 30 Amp Breaker Required, at service panel.

• Delivery Pump/Motor: Single Phase 208/230 VAC, 7.9/7.3 Amps, 60Hz; Branch Circuit 20 Amp Breaker Required, at service panel.

2) **INLET WATER:** Designed to handle potable water up to 2000 ppm TDS; **Hardness** 14 Grains Max; **Silica** 40 PPM Max; **Iron** < 0.1 PPM; **Turbidity** < 1 NTU; **Silt Density Index (SDI)** < 5; **PH Range** 6 - 8.5; **Free Chlorine** < 1.0 ppm.

3) **INLET FLOW REQUIREMENTS:** HS-15000 ≥ 30 GPM.

4) **UNIT/WATER TEMPERATURE:** Min 35°F - Max 100°F (2°F - 38°C). Rated/Operating temperature 77°F (25°C) for rated performance. Cold water line only, (*see schedule*\*).

5) **WATER PRESSURE:** 50 - 75 psig. (1" Line Min.) 60 psig rated pressure regulator P/N 134033 will be required if over 75 psig. For water hammer, install a shock arrester.

6) **CODES:** UL & CUL 508A.

7) **PM KIT:** First year preventative maintenance kit is included (P/N 61301605521).

8) **CLEARANCE:** Minimum 18 inches service clearance on sides. Minimum 40 inches service clearance on top.

9) **FLOOR SINK DRAIN:** 1-1/2" dia. within 6' of Processor & Tank.

10) **APPROVED PIPING MATERIAL:** Schedule 80 PVC for washer applications and L" copper for boiler feed applications.

11) **PRE/POST TREATMENT:** #1 GAC/KDF MixBed, P/N 61301605536 - Qty 1; #2 20" Sediment, P/N 202139 - Qty 1; 10" Post Feeder Kit, P/N 61301605542 is not included. The optional feeder is required for boiler feed (Port Size 1/2" FNPT).

12) **MEMBRANE RECOVERY RATE:** Up to 1:1; **Size:** 4" x 40"; #3 Replacement #61301605464 - 6 needed.

13) **ATMOSPHERIC TANK VOLUME:** 300 Gallon Volume (290 Gallon Usable Storage).

14) **DELIVERY PUMP FLOW:** Delivery Pump 25 GPM @ 40 psi.

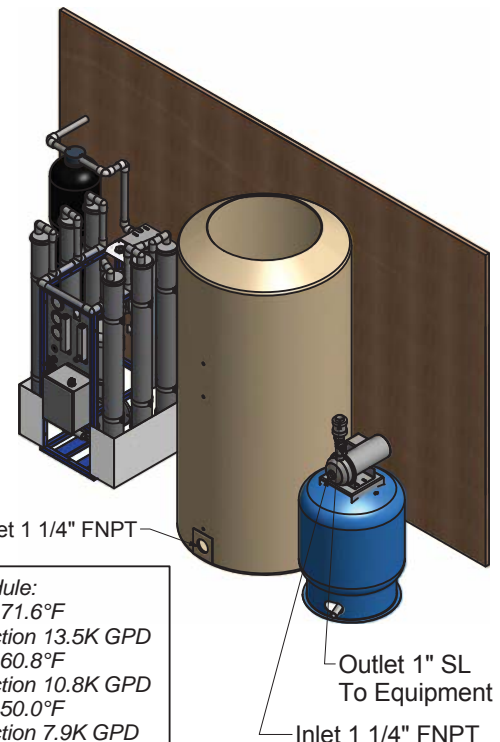
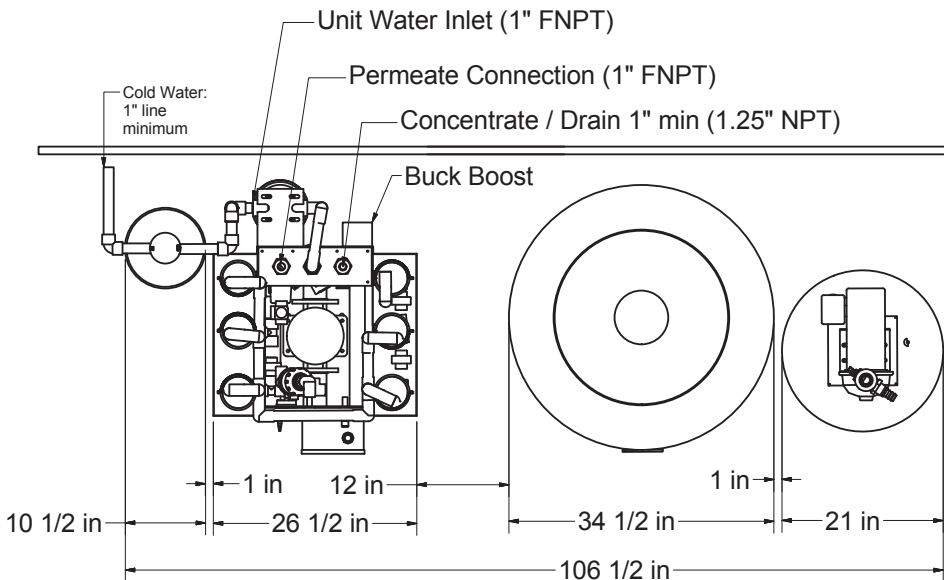

\*Schedule:

Temp. 71.6°F	Production 13.5K GPD
Temp. 60.8°F	Production 10.8K GPD
Temp. 50.0°F	Production 7.9K GPD
Temp. 41.0°F	Production 5.8K GPD

# HS-15000 Water Treatment System PT (P/N 61301605532)

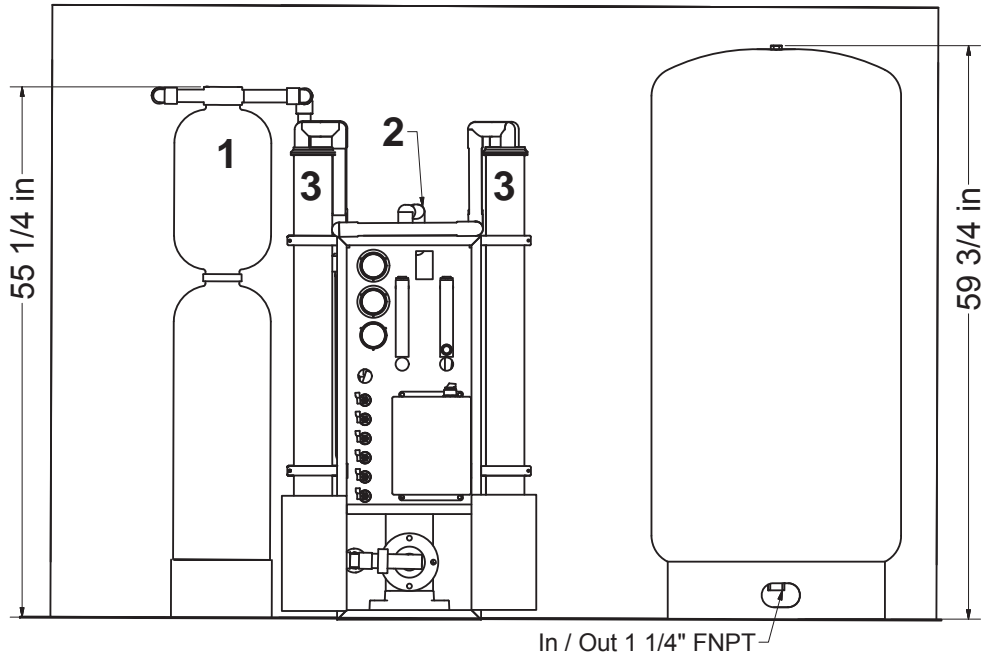
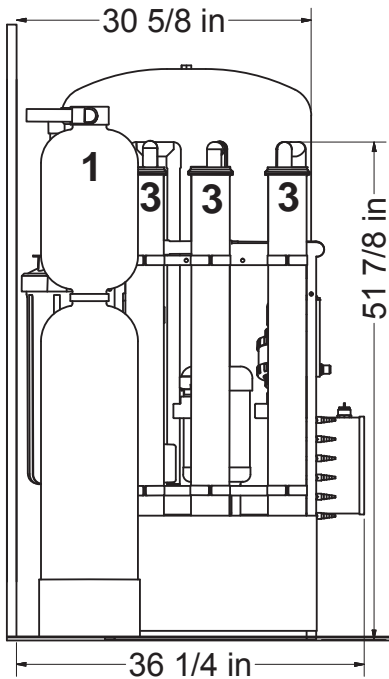

**NOTES:**

1) **ELECTRICAL REQUIREMENTS:**

● RO System: Single Phase 208/230 VAC, 15/13.5 Amps, 60Hz; Branch Circuit 30 Amp Breaker Required, at service panel.

2) **INLET WATER:** Designed to handle potable water up to 2000 ppm TDS; **Hardness** 14 Grains Max; **Silica** 40 PPM Max; **Iron** < 0.1 PPM; **Turbidity** < 1 NTU; **Silt Density Index (SDI)** < 5; **PH Range** 6 - 8.5; **Free Chlorine** < 1.0 ppm.

3) **INLET FLOW REQUIREMENTS:** HS-15000 ≥ 30 GPM.

4) **UNIT/WATER TEMPERATURE:** Min 35°F - Max 100°F (2°F - 38°C). Rated/Operating temperature 77°F (25°C) for rated performance. Cold water line only, (*see schedule*\*).

5) **WATER PRESSURE:** 50 - 75 psig. (1" Line Min.) 60 psig rated pressure regulator P/N 134033 will be required if over 75 psig. For water hammer, install a shock arrester.

6) **CODES:** UL & CUL 508A.

7) **PM KIT:** First year preventative maintenance kit is included (P/N 61301605521)

8) **CLEARANCE:** Minimum 18 inches service clearance on sides. Minimum 40 inches service clearance on top.

9) **FLOOR SINK DRAIN:** 1-1/2" dia. within 6' of Processor & Tank.

10) **APPROVED PIPING MATERIAL:** Schedule 80 PVC for washer applications and L" copper for boiler feed applications.

11) **PRE/POST TREATMENT:** #1 GAC/KDF MixBed, P/N 61301605536 - Qty 1; #2 20" Sediment, P/N 202139 - Qty 1; 10" Post Feeder Kit, P/N 61301605542 is not included. The optional feeder is required for boiler feed (Port Size 1/2" FNPT).

12) **MEMBRANE RECOVERY RATE:** Up to 1:1 Size 4" x 40"; #3 Replacement #61301605464 - 6 needed.

13) **PRESSURE TANK SIZE:** 119 Gallon Volume (63 Gallon Usable Storage). **Pressure Switch set to:** On @ 40 psi, Off @ 60 psi.

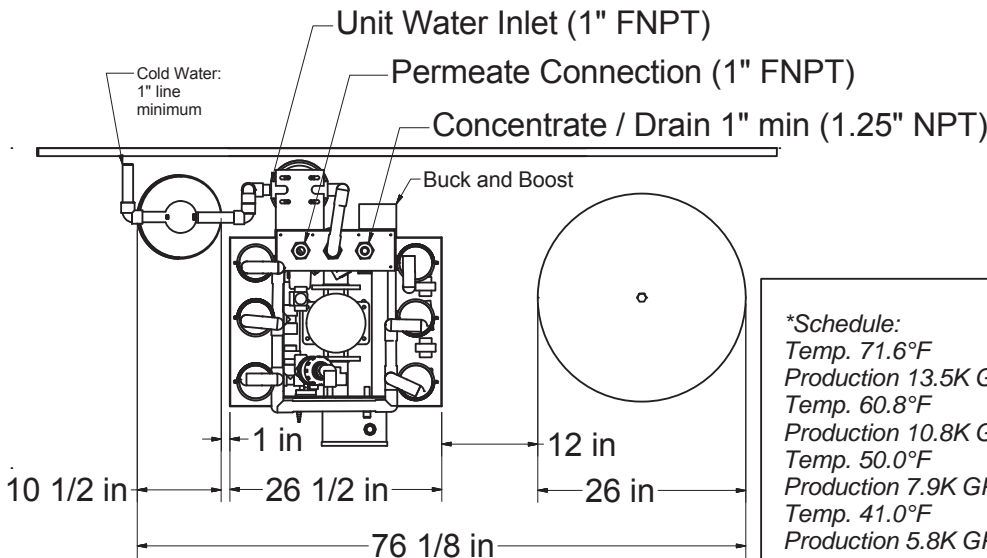

\*Schedule:

Temp. 71.6°F	Production 13.5K GPD
Temp. 60.8°F	Production 10.8K GPD
Temp. 50.0°F	Production 7.9K GPD
Temp. 41.0°F	Production 5.8K GPD

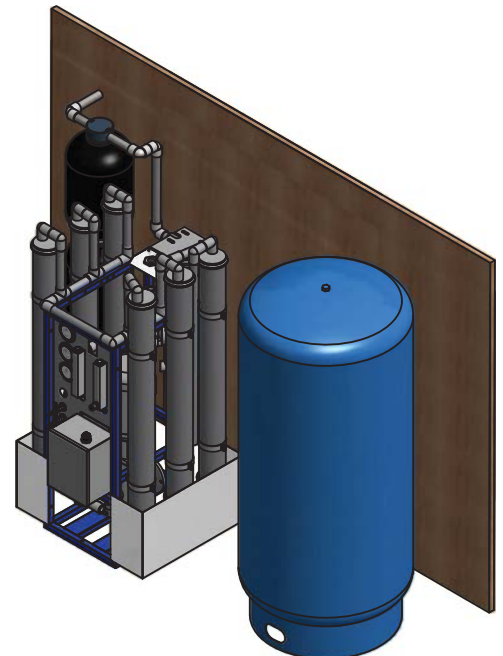



Getinge is the world's leading provider of solutions for effective cleaning, disinfection and sterilization in the healthcare and life science sectors. We are dedicated to helping our customers provide maximum productivity in the most cost-efficient way. We do this by offering well thought through and customized solutions. This means that we are with our customers all the way from architectural planning and education to traceability and support - with complete solutions, long-term commitment and global presence.

**Getinge USA, Inc.**  
1777 East Henrietta Road  
Rochester, New York 14623-3133  
U.S.A.  
Phone: 800.475.9040  
Fax: 585.272.5033

**Getinge Canada, Ltd.**  
6685 Millcreek Drive, Unit 3  
Mississauga, ON  
L5N 5M5  
Phone: 905.363.4150

**GETINGE**  
GETINGE GROUP

[www.getingeusa.com](http://www.getingeusa.com)

GETINGE GROUP is a leading global provider of products and systems that contribute to quality enhancement and cost efficiency within healthcare and life sciences. We operate under the three brands of ArjoHuntleigh, GETINGE and MAQUET. ArjoHuntleigh focuses on patient mobility and wound management solutions. GETINGE provides solutions for infection control within healthcare and contamination prevention within life sciences. MAQUET specializes in solutions, therapies and products for surgical interventions and intensive care.